

# Build a nixie power supply

To drive nixie tubes or neon lamps you need a DC power supply of around 170 volts for consistent and fast tube striking. But where to get such a supply? This simple switchmode converter provides the required voltage with enough current to supply most projects.

This kit allows you to make a very simple switchmode boost (step-up) converter for powering nixie tubes and similar displays that require voltages between 100 and 200 Volt DC. It uses very readily available parts which can be bought from almost any electronics components store should the need arise for replacements.

## How it works

The circuit is designed around one of the most common ICs on the planet—the 555 timer chip. While several decades old, this chip still finds uses in a great many areas, including simple converters like this one.

The 555 is configured as an astable oscillator which oscillates at a frequency (around 45kHz) determined by resistors R1 and R2, and capacitor C2. The 555's output directly drives a high voltage MOSFET, Q1, that switches the current through an inductor, L1.

When the FET is on, current flows from V+ through the inductor to ground. As the current in the inductor builds up, the FET then turns off.

When the FET turns off, the current flowing through the inductor tries to continue to flow but can't flow through the FET, so the voltage on the FET's drain

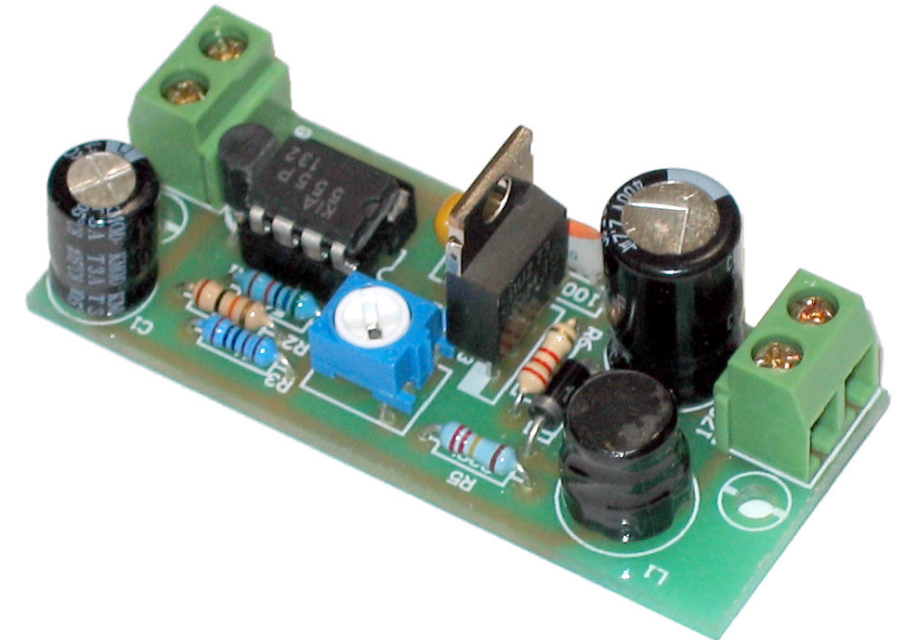

terminal rises until the ultrafast diode, D1 becomes forward biased. This allows the energy contained in the coil to be dumped into the high voltage capacitor, C4.

This cycle continues until the voltage across C4 reaches a value set by trimpot VR1. R4, R5 and VR1 form the feedback divider for the circuit, and are chosen such that the voltage across C4 is divided down to around 0.7 volts. This voltage is applied

to transistor Q2, a BC547. When the voltage across C4 rises to the point where the voltage from the divider is enough to turn Q2 on, then Q2 pulls down the Control pin of the 555, stopping it from oscillating and shutting down the converter.

As soon as this happens, the voltage across C4 begins to fall, as does the voltage into the base of Q2, and so Q2 turns off, allowing the converter to restart. This is how the circuit regulates the voltage, and in practice it works quite well.

Resistor R6 and capacitor C3 form a simple snubber network, while C1 is the main reservoir cap for the circuit. And that's about all there is to it!

## Building it

Well, there is not much to say here, just get the components in their appropriate places and the right way around (for the polarised components like the diode, electrolytic capacitors, transistors and IC) and solder them into place. Make sure there are no shorts between IC pins or other places on the board. When you have checked and double checked your work, you can then give the unit a test.

## The smoke test

Place the board on an insulating surface (clean, dry wood or plastic is fine)

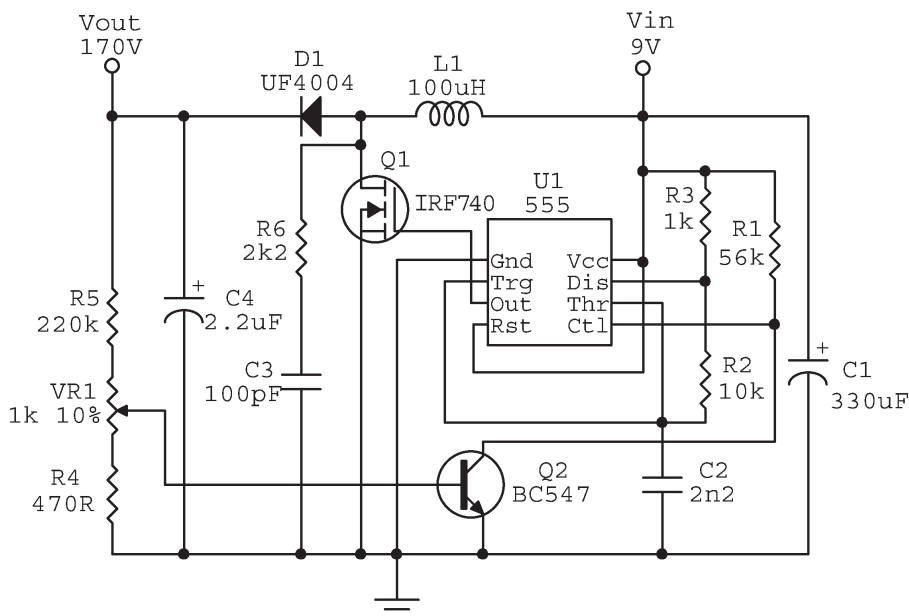

The circuit diagram for the switchmode converter.

and, after making sure the trimpot is centred, connect a 9 to 12 volt DC source to the input terminal block. It is best to use a current limited supply to start with, in case there is a problem. Do not connect the circuit to a battery or other high current supply without having tested it first!

Now, take your multimeter and check the output voltage. It could be anywhere between 100 and 200 Volt DC. If there is no voltage on the output, check that the 555 is oscillating (you do have a logic probe of course!). If not, find the problem and fix it.

Once you get a high voltage output, make sure it is adjustable from around 100 volts to 200 volts. The lower limit varies somewhat with different components, one prototype couldn't be adjusted below 145 volts.

Note that, as the kit is supplied with a 400 volt MOSFET, the output can exceed 200 volts, but don't use the kit for voltages above this.

The final test involves connecting a load to the supply, such as a nixie tube via a 22k resistor. If the supply drives the load, then you're in business! Of course, turn the supply off and allow the voltage to drop to a safe level before making any connections!

Note that the voltage will vary a bit with load, but it should not swing by more than a few volts from 0 to 10mA load.

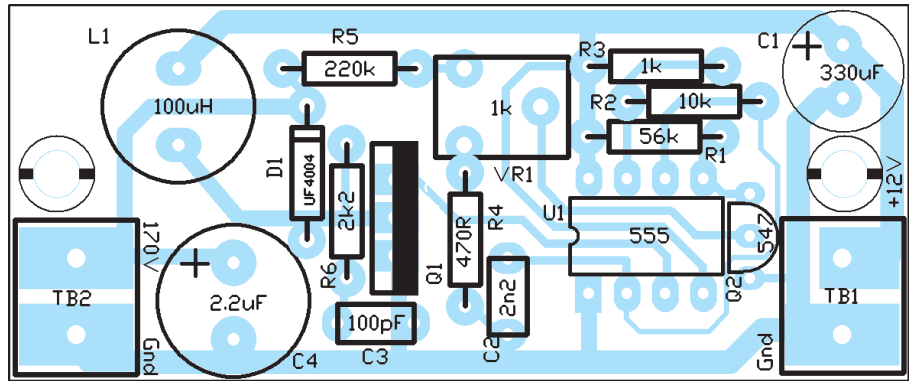

The board and overlay shown larger than actual size.

### Parts list

Part #	Value/description
U1	555 timer
Q1	IRF740
Q2	BC547
D1	UF4004
C1	330uF 16V
C2	2.2nF
C3	100pF
C4	2.2uF 250V
R1	56k
R2	10k
R3	1k
R4	470ohm
R5	220k
R6	2.2k
VR1	1k trimpot
L1	100uH
TB1, TB2	2-way terminal block
SOC1	8 pin IC socket
PCB1	Circuit board
	High voltage label

### Warning!

This circuit, while not as dangerous as mains power, provides enough energy to potential kill a person should they be connected between the high voltage output and ground in the right way, so be careful when working on this circuit!

Always, turn off the power and wait for the high voltage output to drop before making any changes to the circuit.

When completed, the circuit must be mounted inside an insulated case with properly insulated terminals to prevent anyone accidentally coming into contact with the high voltage output!

# Identifying the parts of your power supply kit

The following guide should help you to identify the parts and assemble it successfully.

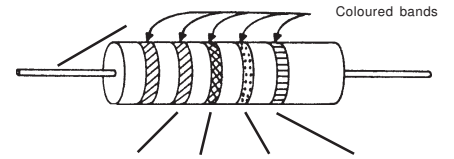

Colour	Hundreds	Tens	Units	Multiplier	Tolerance
Black	0	0	0	1	20%
Brown	1	1	1	10	1%
Red	2	2	2	100	2%
Orange	3	3	3	1000	
Yellow	4	4	4	10,000	
Green	5	5	5	100,000	
Blue	6	6	6	1,000,000	
Violet	7	7	7		
Grey	8	8	8		
White	9	9	9		
Gold				0.1	5%
Silver				0.01	10%

## Resistors

The coloured bands represent numbers and multipliers as shown in the table. Some resistors have four bands (two digits, a multiplier band and a tolerance band) while some resistors have five bands. Five-band resistors are read in the same manner as four-band resistors, except that the first three bands are digits, the fourth a multiplier and the fifth the tolerance band.

## Diode

The UF4004 will be marked UF4004. Note that other similar diodes may be substituted. They will work fine in this kit. It will be black with silver markings.

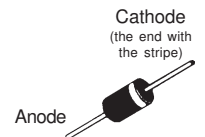

The 1 amp fast diode is usually black plastic.

## Capacitors

The 2.2nF (2n2) capacitor will be marked 2n2 or 222. The 100pF capacitor is the small light grey one with the orange or black top. Neither of these are polarised and can be installed either way around.

The 330uF and 2.2uF electrolytic capacitors are larger black barrel diodes and are clearly marked. They are polarised and must be installed the correct way around. The longer lead is positive, or if both leads are the same, the negative is clearly marked with a big line or minus symbol running down the side of the case.



## Inductor

The 100uH inductor is similar in size and shape to the 330uF capacitor, but it has no markings. It is not polarised, so can be fitted either way around.

## The FET

The FET will be marked IRF740. Note that the FET must be installed the correct way around, with the back of the device facing towards the 555.

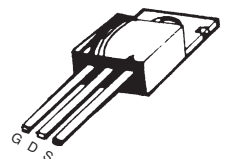

## The 555 timer

This is the 8 pin device. Note that it must be installed the correct way around. Pin 1 is marked with a small dot, and the pin 1 end of the chip will have a semicircular notch or mark. The IC socket also has this notch, so make sure it is installed the correct way around also, as this notch is used to indicate device polarity.

